

Flanged Vibrators

For the ceramic industry



EX-STOCK DELIVERY
2 YEAR WARRANTY



SPECIFICALLY DESIGNED FOR CERAMIC INDUSTRY

Suitable for the most popular sieve brands



MAINTENANCE FREE

Grease for life



THE BEST PERFORMANCE

To ensure higher productivity

**VIBRATORS
FOR CERAMIC
CIRCULAR SIEVES**



OLI



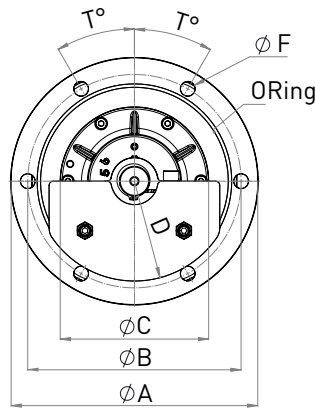
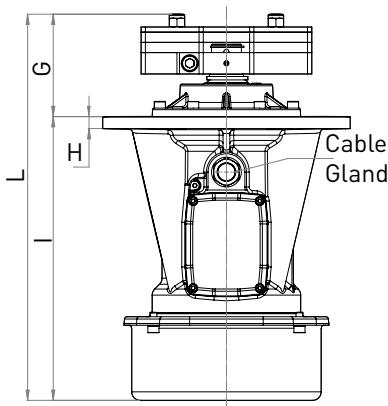

Wm (kgcm)		Model		Poles	Total Centrifugal Force (kg)		UP Centrifugal Force (kg)		DOWN Centrifugal Force (kg)		RPM		Weight (kg)		Input Power (kW)		Nominal Current A max. (A)		Ia / In (Ampere)		Cable Gland
50Hz	60Hz	50Hz	60Hz		n°	50Hz	60Hz	50Hz	60Hz	50Hz	60Hz	50Hz	60Hz	50Hz	60Hz	50Hz (400V)	60Hz (460V)	50Hz	60Hz	Metric	
9	6	MVE 450/3E-SL-40AD	MVE 450/36E-SL-40AD	2	463	456	362	355	101	101	3,000	3,600	15.0	14.5	0.50	0.58	0.96	0.97	3.5	3.5	M20
11	8	MVE 600/3E-SL-40AD	MVE 600/36E-SL-40AD	2	545	565	442	419	101	144	3,000	3,600	15.5	15.0	0.50	0.58	0.96	0.97	3.5	3.5	M20
22	16	MVE 1100/3E-SL-50AD	MVE 1100/36E-SL-50AD	2	1,125	1,129	855	868	270	260	3,000	3,600	25.7	24.8	0.95	1.15	1.85	1.95	4.0	4.2	M25
29	20	MVE 1500/3E-SL-60BR	MVE 1500/36E-SL-60BR	2	1,468	1,477	1,227	1,231	241	246	3,000	3,600	42.4	41.0	1.54	1.60	2.94	2.61	5.2	5.0	M25
65	42	MVE 800/15E-SL-50AD	MVE 800/18E-SL-50AD	4	817	765	585	575	230	188	1,500	1,800	29.6	26.7	0.64	0.77	1.40	1.35	3.8	3.8	M25
123	82	MVE 1500/15E-SL-60BR	MVE 1500/18E-SL-60BR	4	1,544	1,500	1,222	1,166	322	333	1,500	1,800	51.0	47.0	0.70	0.84	1.78	1.78	4.0	4.0	M25
196	139	MVE 2500/15E-SL-70BT	MVE 2500/18E-SL-70BT	4	2,469	2,523	1,234	1,262	1,234	1,262	1,500	1,800	78.0	73.0	1.90	2.30	3.70	3.30	6.0	6.1	M25

Model		Size	DIMENSIONAL SPECIFICATIONS													
50Hz	60Hz		A	B	C	D	T	F	G (mm)		H	I	L (mm)		Holes	O Ring
		mm	mm	mm	mm	degrees	mm	50Hz	60Hz	mm	mm	50Hz	60Hz			
MVE 450/3E-SL-40AD	MVE 450/36E-SL-40AD	40	232	205	160	73	30	14	-	12	280	280	280	6	4700	
MVE 600/3E-SL-40AD	MVE 600/36E-SL-40AD	40	232	205	160	73	30	14	-	12	280	280	280	6	4700	
MVE 1100/3E-SL-50AD	MVE 1100/36E-SL-50AD	50	232	205	168	93	30	13	71	15	322	393	393	6	4700	
MVE 1500/3E-SL-60BR	MVE 1500/36E-SL-60BR	60	294	270	174	93	17.5/55	15	103	14	333	435	435	8	4950	
MVE 800/15E-SL-50AD	MVE 800/18E-SL-50AD	50	232	205	168	86	30	14	118	103	15	322	440	425	6	4700
MVE 1500/15E-SL-60BR	MVE 1500/18E-SL-60BR	60	294	270	174	117	17.5/55	15	130	110	14	333	463	443	8	4950
MVE 2500/15E-SL-70BT	MVE 2500/18E-SL-70BT	70	340	305	200	125	45	17	140	18	420	560	560	8	41050	

MVE 'S' SERIES FOR THE CERAMIC INDUSTRY

APPLICATION Circular vibrating sieves.

PROBLEM SOLVING Quick and easy installation; maintenance free (grease for life).

FEATURES

INPUT VOLTAGE 400V (50Hz) or 460V (60Hz)

AMBIENT TEMPERATURE -20 °C / +40 °C

ENCLOSURE PROTECTION IP 66

THERMAL PROTECTION PTC Termistor 130 °C (above size 60)

INSULATION CLASS F

WHEN YOU NEED IT, WHERE YOU NEED IT.

WWW.OLIVIBRA.COM