



MAIN FEATURES

- High reliability • Good performance
- Low noise level • Lightweight
- Simple construction

APPLICATIONS

- Air-compressors • Pumps • Fans
- Medical apparatus & instruments
- Domestic appliances • Small machines

TECHNICAL CHARACTERISTICS

- Protection degree IP55
- Insulation class F
- S1 duty
- Maximum ambient temperature: +40 °C
- Installation ≤1000 m a.s.l.
- Starting torque to 0,7

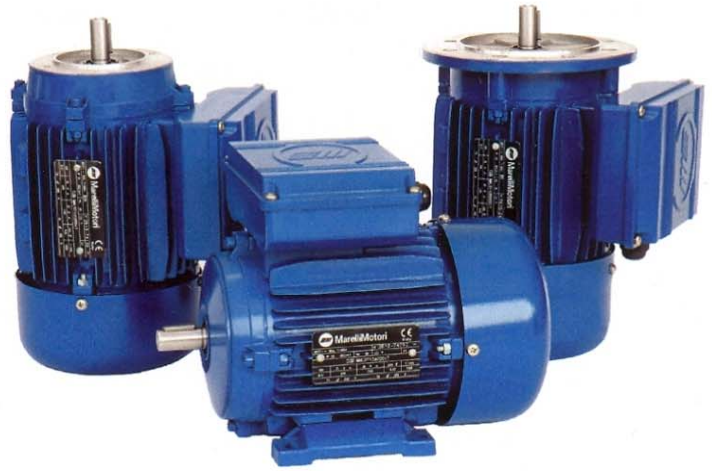

OVERALL DIMENSIONS

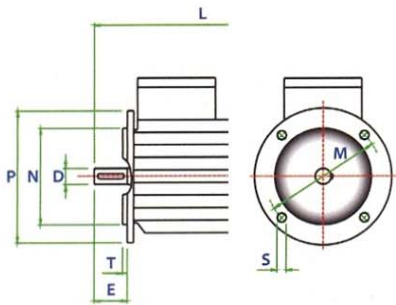
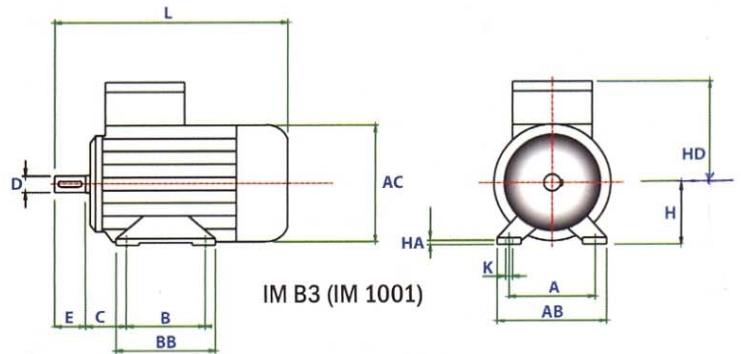

IM B5 (IM 3001)

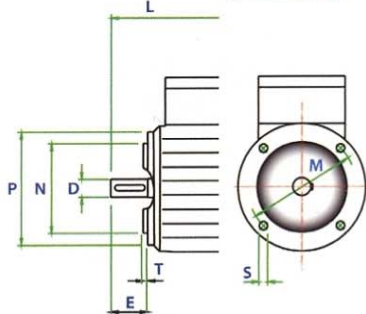

IM B14 (IM 3601)

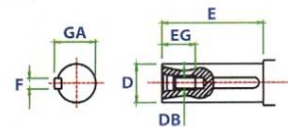

SHAFT EXTENSION

DIMENSIONS																													
FRAME SIZE		B3										B5					B14					TAPPED HOLES AS PER DIN 332							
IEC	POLES	A	AB	AC	B	BB	C	H	HA	HD	K	L	M	N	P	S	T	M	N	P	S	T	D	TOLL.	E	Fh9	GA	DB	EG
63	2-4	100	120	130	80	100	40	63	7	116	7	212	115	95	140	10	3	75	60	90	M5	2,5	11	j6	23	4	8,5	M4	10
71	2-4	112	132	145	90	110	45	71		123		255	130	110	160		3,5	85	70	105	M6		14		30	5	11	M5	12
80	2-4	125	157	165	100	125	50	80	8	143	10	290	165	130	200	12	3,5	100	80	120	M6	3	19	j6	40	6	15,5	M6	16
90	S 2-4 L 2-4	140	172	185	100 125	155	56	90	10	150		335						365	115	95	140	M8	3		24	50	8	20	M8
100L	2-4	160	196	205	140	180	63	100	12	160	12	445	215	180	250	15	4	130	110	160	M8	3,5	28	j6	60	8	24	M10	22
112M	2-4	190	222	230			70	112										183	453	130	110	160	M8		3,5	28	60	8	24

MARELLI MOTORI reserves the right to change the design, technical specification and dimensions in order to update or improve its products without prior notice.